

■	床 - 床	SL-SJ50F (高荷重仕様)	種別： ステンレス 仕上げ： HL	アンカー固定間隔： @ ≤ 560 mm	S= 1:2
---	-------	------------------	----------------------	-------------------------	--------

可動図	可動量
	+47mm -16mm
	+フリー -フリー
	+20mm -20mm

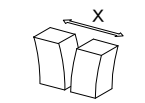
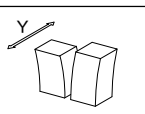
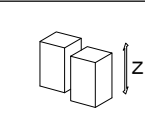
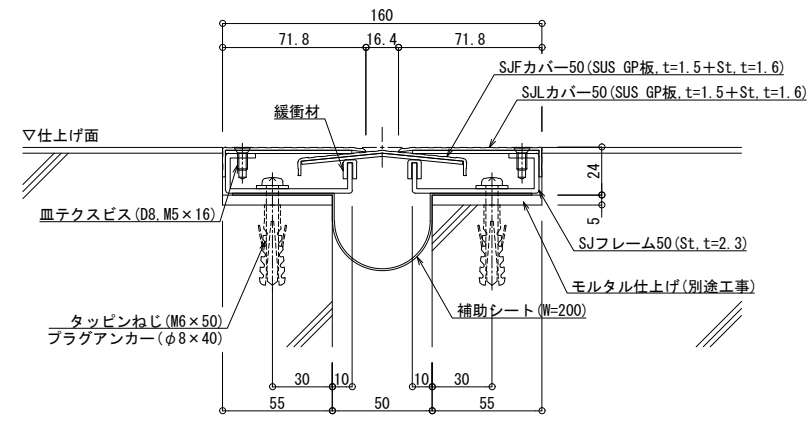

制定: 2017.9.20
 改定: 2020.10.23