

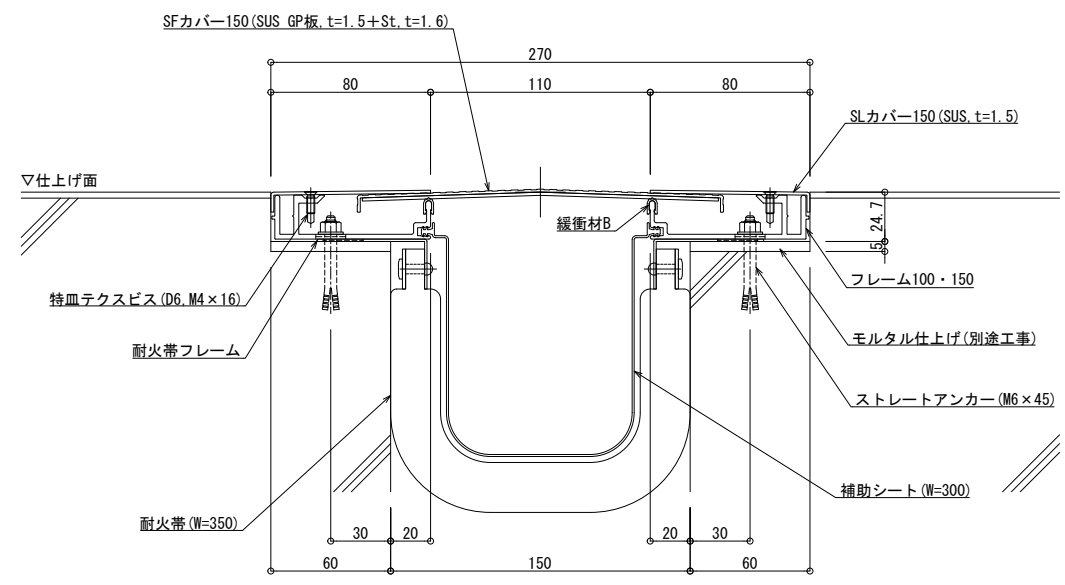

■	床 - 床	SL-S150F (耐火仕様) 25mm	種別： ステンレス 仕上げ： HL	アンカー固定間隔： @ ≤ 560 mm	S= 1:2
---	-------	----------------------	----------------------	-------------------------	--------

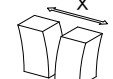
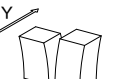

可動面	可動量
	+63mm -32mm
	+フリー -フリー
	+20mm -20mm

製定: 2022.02.02 改定: