

■	床 - 床	SL-S200F	種別： ステンレス 仕上げ： HL	アンカー固定間隔： @ ≤ 560 mm	S= 1:2
---	-------	----------	----------------------	-------------------------	--------

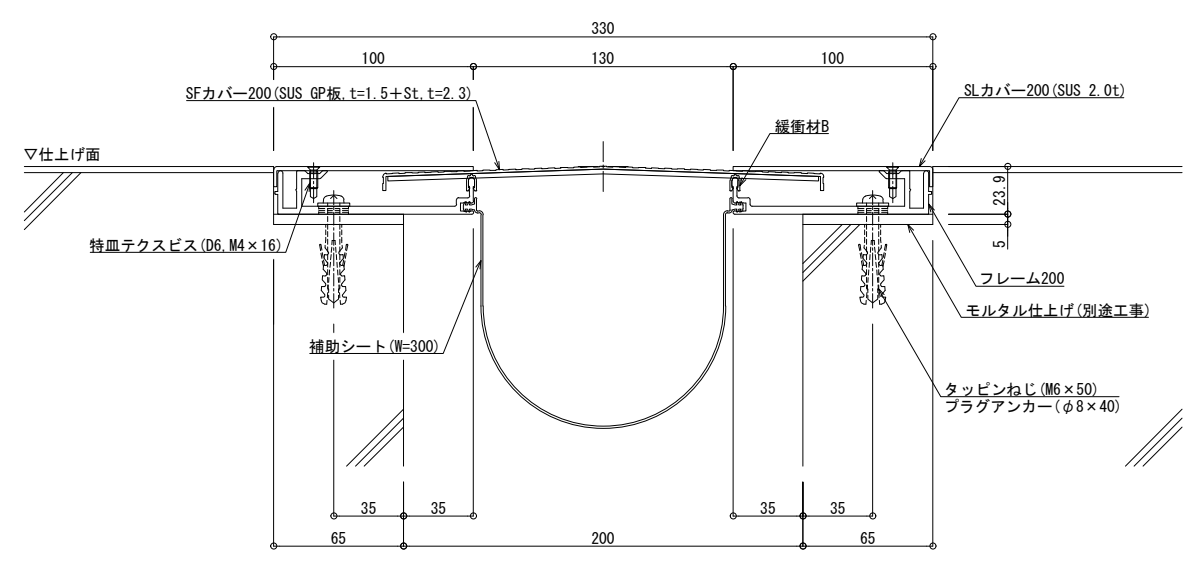
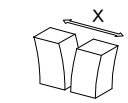
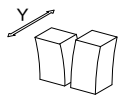
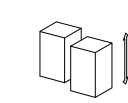

可動図	可動量
	+80mm -57mm
	+フリー -フリー
	+20mm -20mm

制定: 2017.9.20
 改定: 2020.10.23