

床コーナー

SL-SH200FC

アンカー固定間隔：
@ ≤ 560 mm

S= 1:2

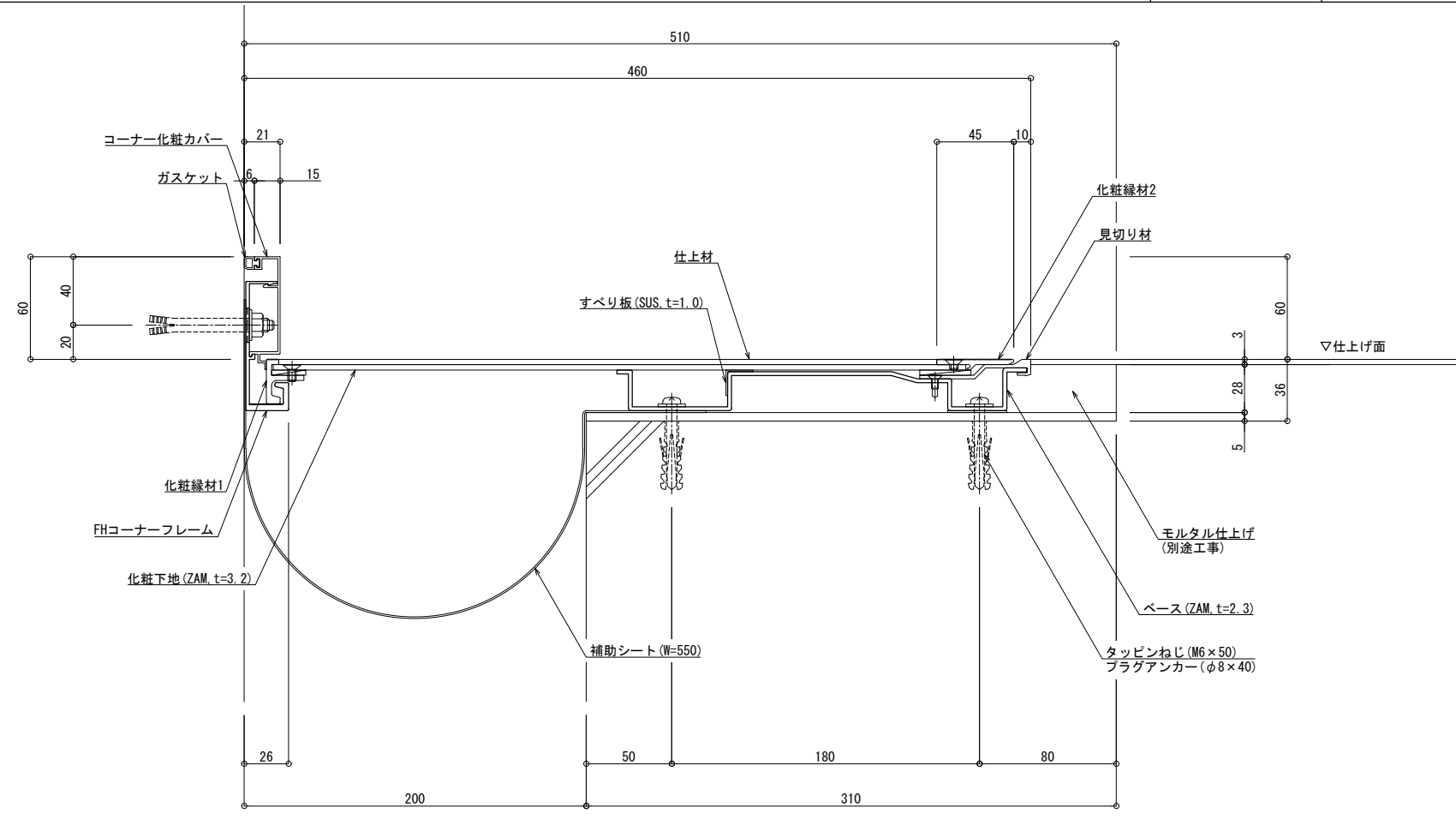

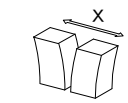
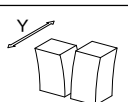
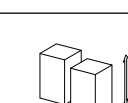
可動図	可動量
	+200mm -200mm
	+200mm -200mm
	+30mm -30mm

制定: 2017.9.20 改訂: 2020.10.23