

3) 高強度支持金具

(支持間隔3,900mm以内 (A) 寸法、RC限定) / 2,900mm以内)

4) PC板への取付け

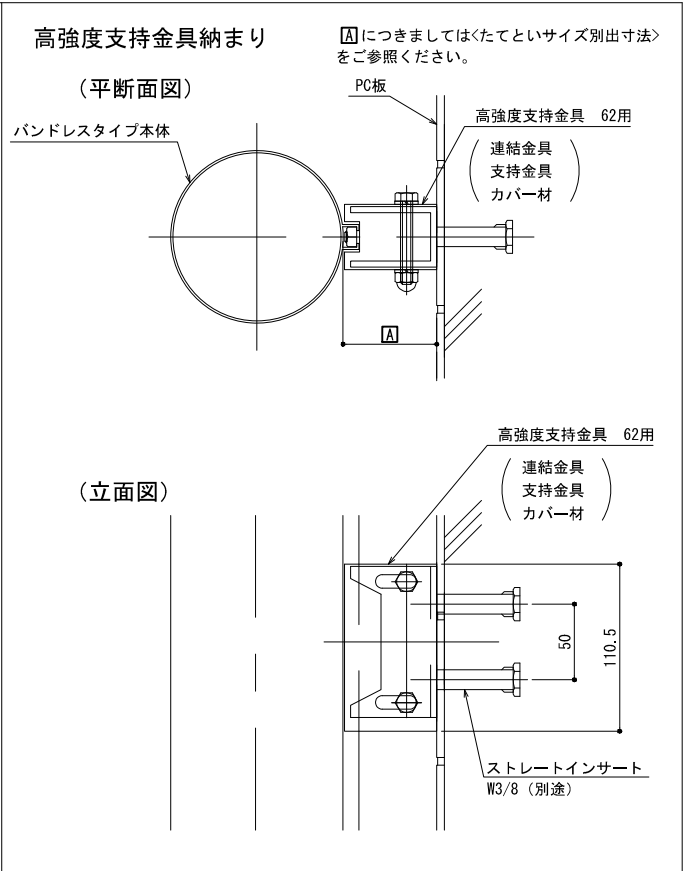
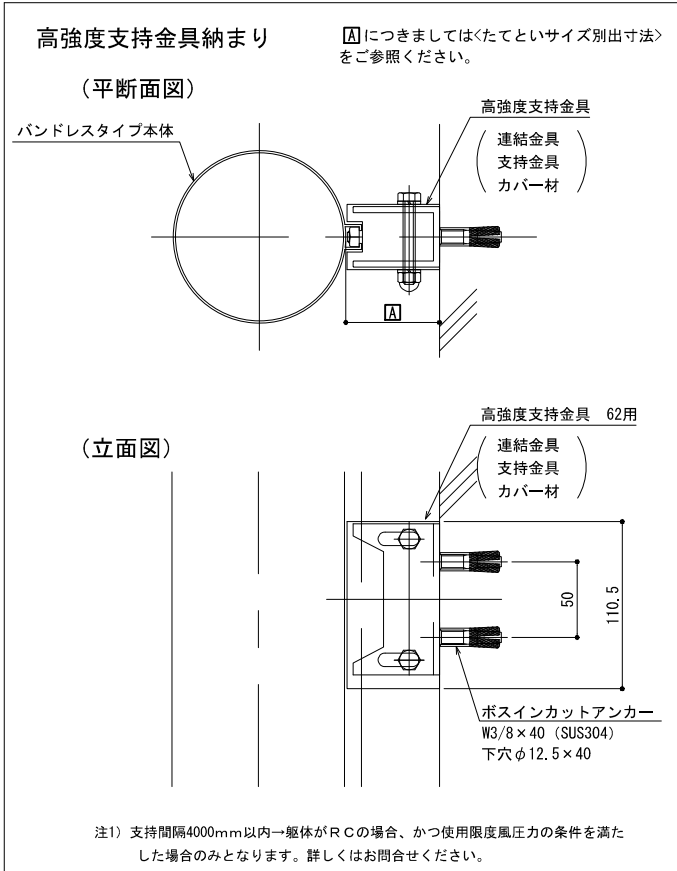

5) 一本ボルト支持金具RC用 (支持間隔 2,900mm以内)

